

**IT - ISTRUZIONI DI MONTAGGIO**  
**EN - ASSEMBLY INSTRUCTIONS**  
**DE - MONTAGEANLEITUNG**  
**FR - INSTRUCTIONS DE MONTAGE**

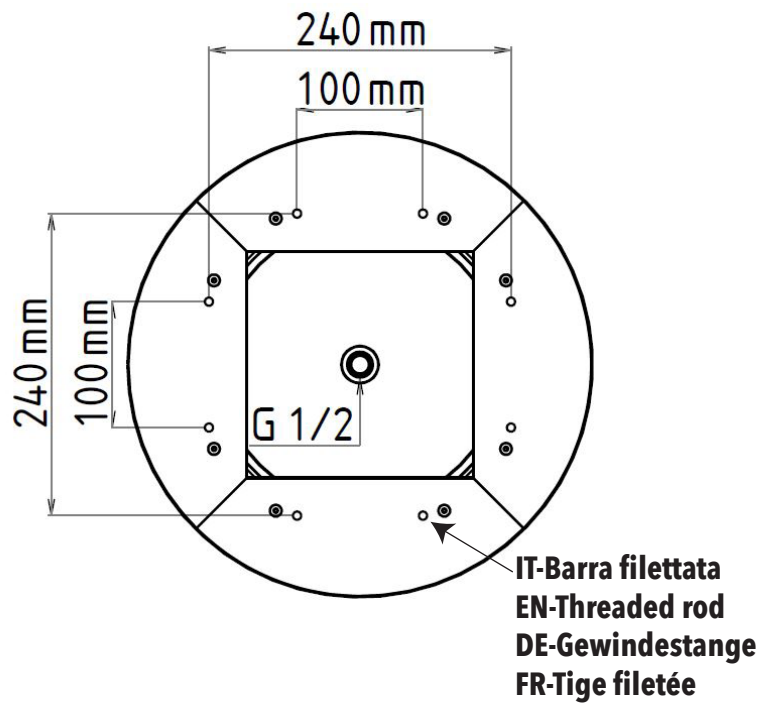

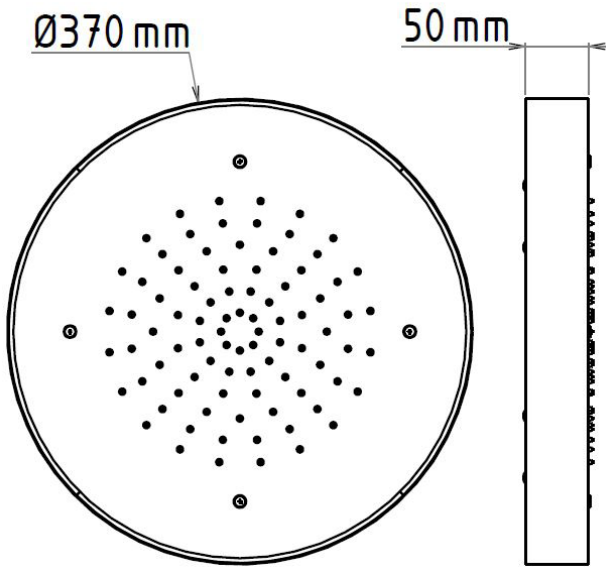

MAX 70°C  
BEST 38/40°C



MIN 1 Bar  
MAX 5 Bar  
BEST 3 Bar

IT-Dimensioni foro  
EN-Hole size  
DE-Lochgröße  
FR-Taille du trou

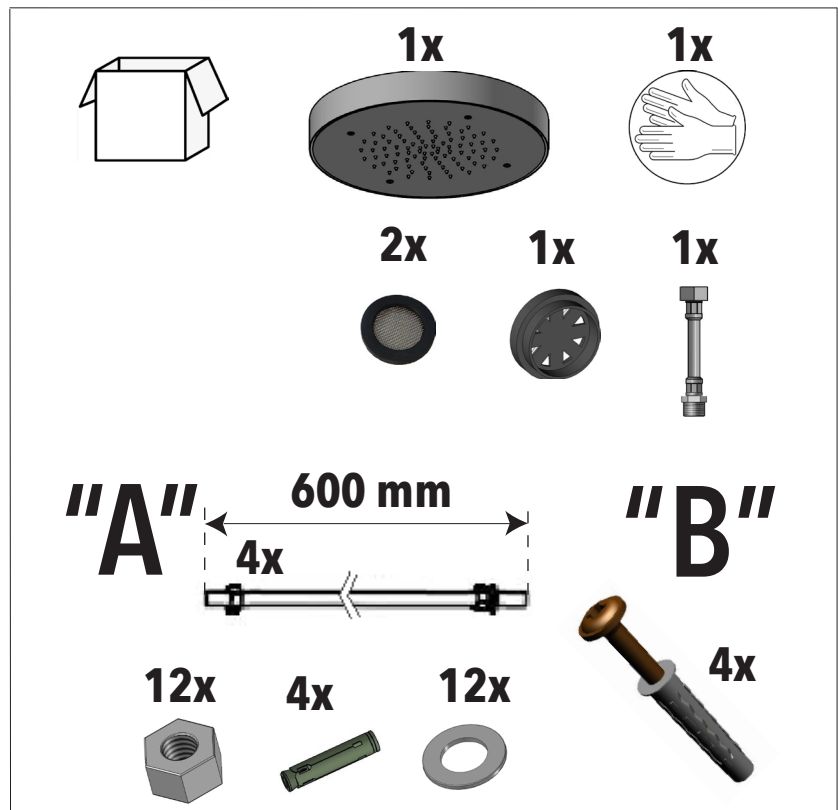
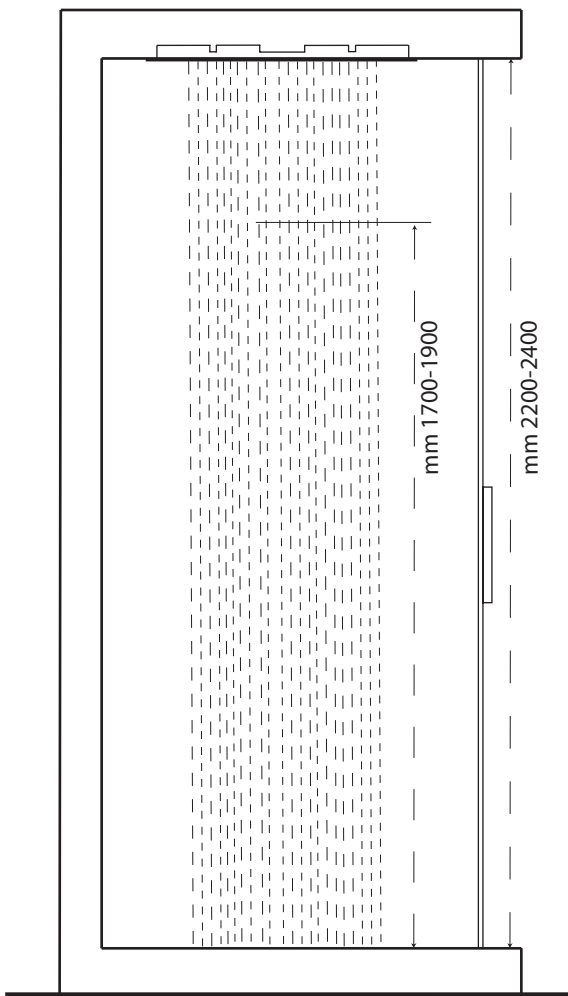
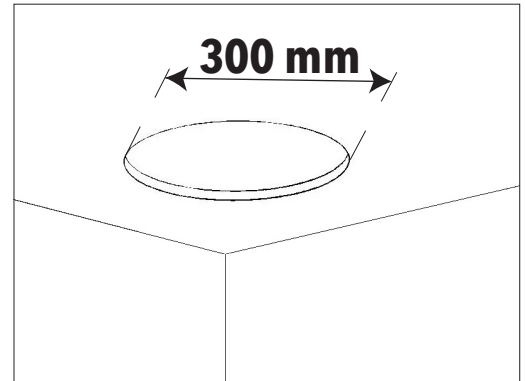

IT - L'apparechio deve essere installato da personale abilitato ai sensi e per l'effetto delle leggi in vigore.  
EN - According to the law, all installation and maintenance operations require a qualified person.  
DE - Das Gerät muss von qualifiziertem Personal gemäß den geltenden Gesetzen installiert werden.  
FR - L'appareil doit être installé par du personnel qualifié conformément et pour l'effet des lois en vigueur.

