

**IT - ISTRUZIONI DI MONTAGGIO**  
**EN - ASSEMBLY INSTRUCTIONS**  
**DE - INSTALLATIONSANLEITUNG**  
**FR - INSTRUCTIONS DE MONTAGE**

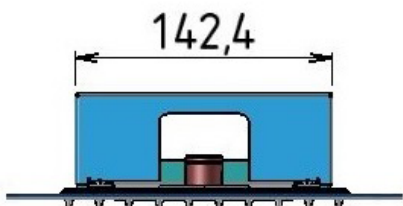

**SAFETY VALVE**

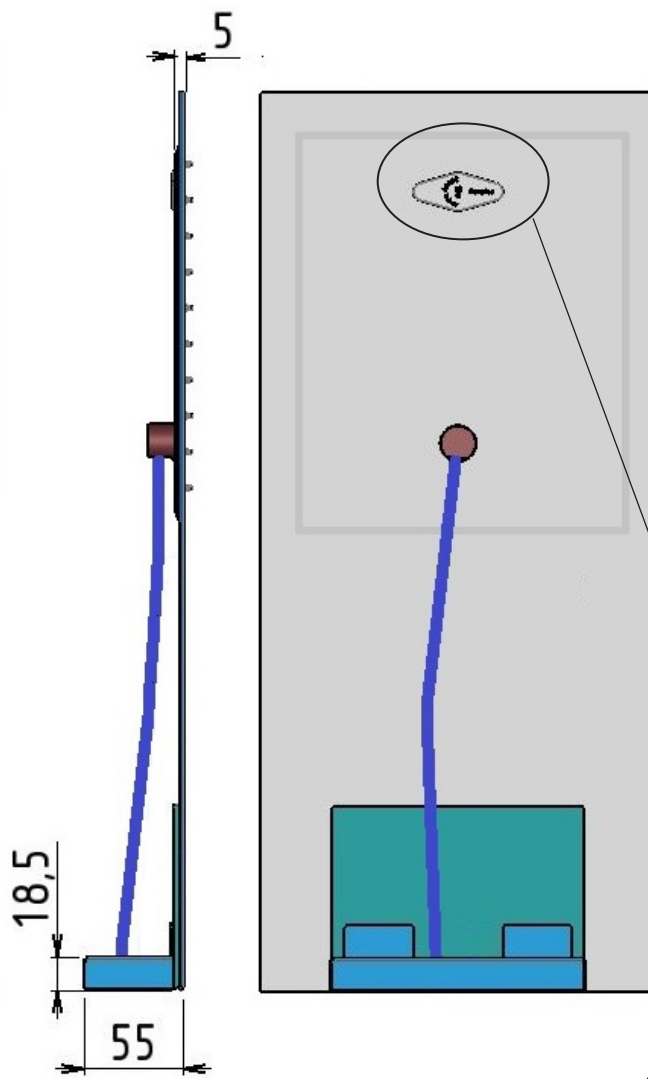

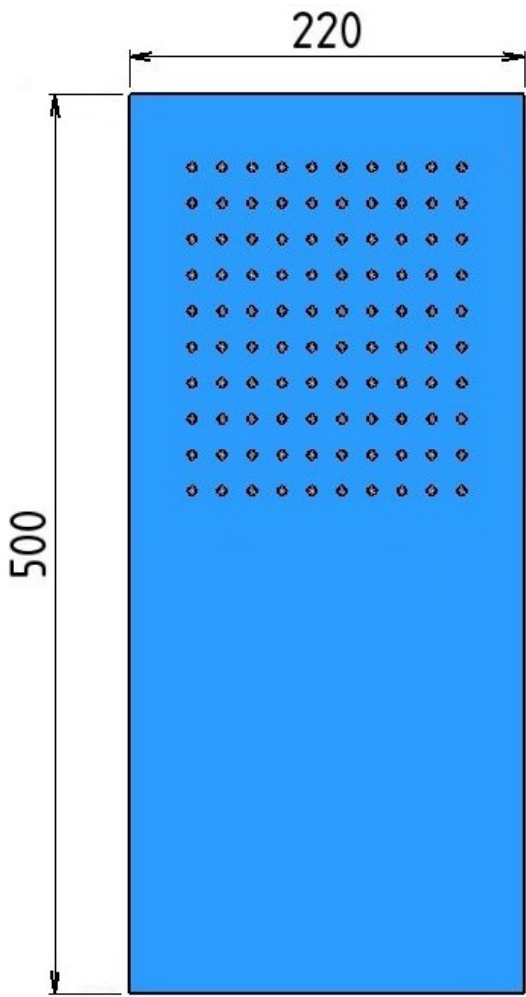

**MAX 70°C**  
**BEST 38/40°C**



**MIN 1 Bar**  
**MAX 5 Bar**  
**BEST 3 Bar**

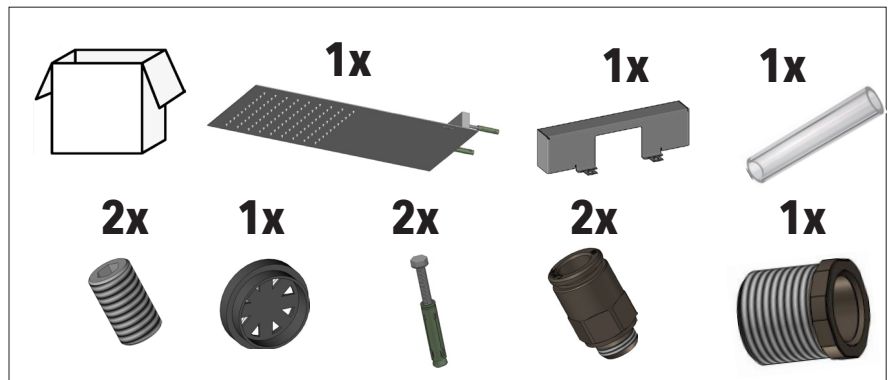

**IT - L'apparechio deve essere installato da personale abilitato ai sensi e per l'effetto delle leggi in vigore.**  
**EN - According to the law, all installation and maintenance operations require a qualified person.**  
**DE - Das Gerät muss von qualifiziertem Personal gemäß den geltenden Gesetzen installiert werden.**  
**FR - L'appareil doit être installé par du personnel qualifié conformément et pour l'effet des lois en vigueur.**

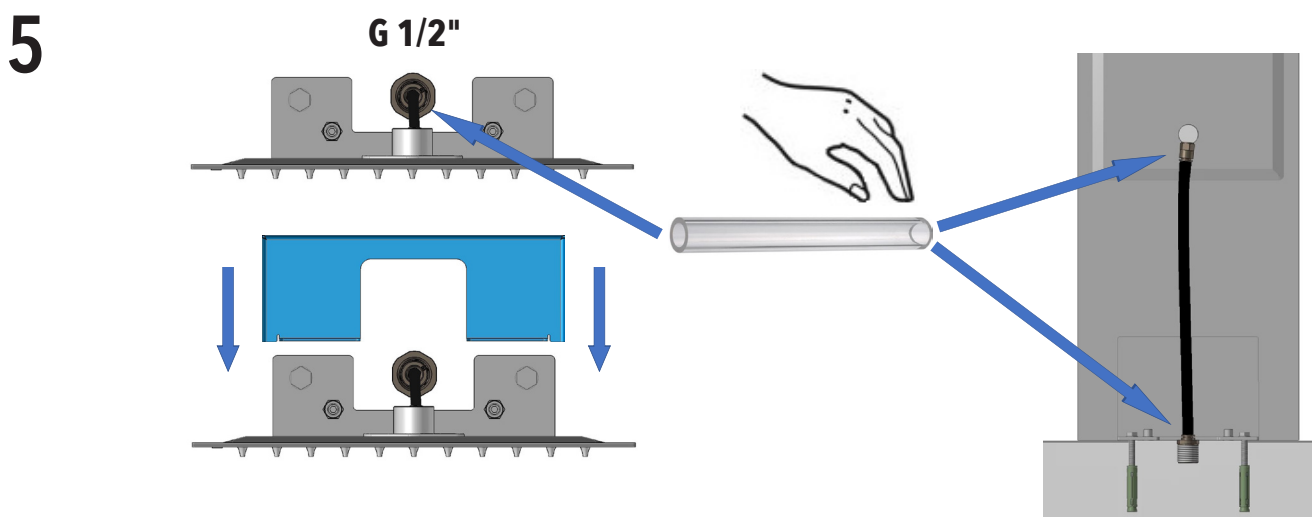
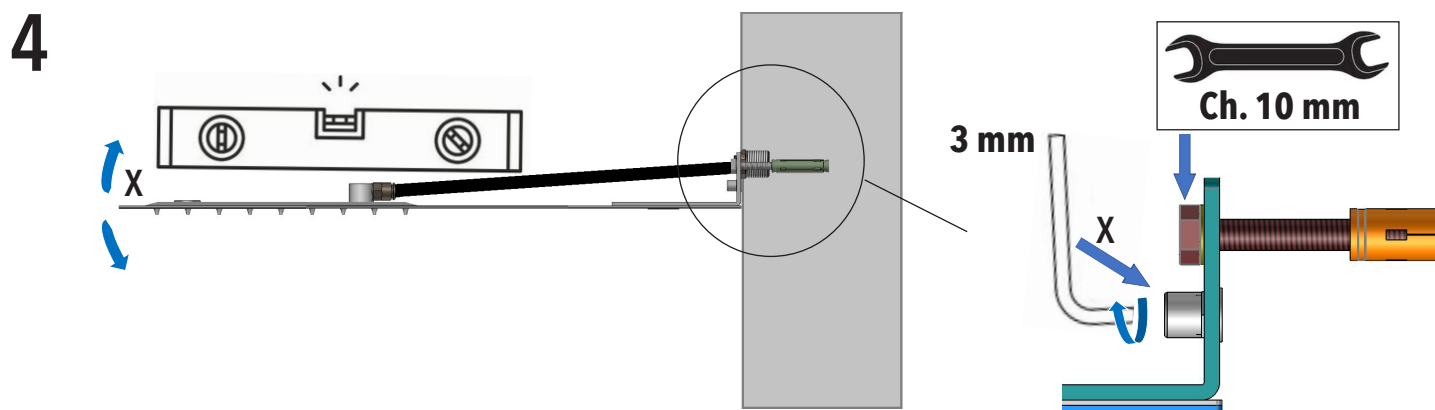
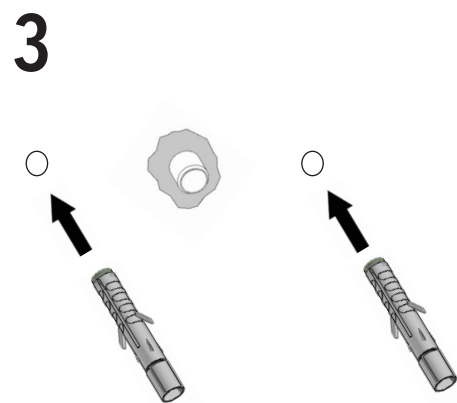
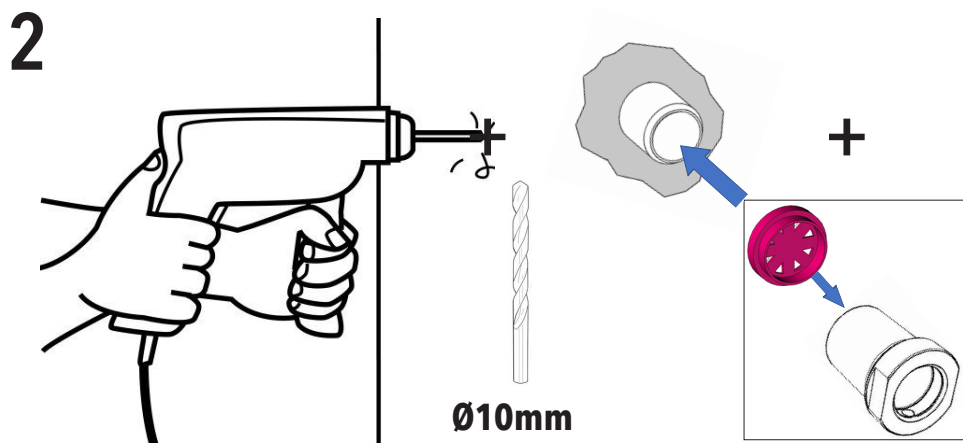
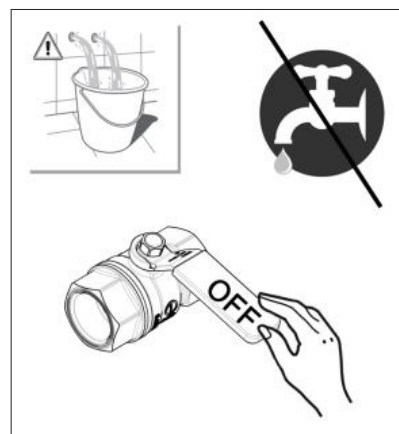
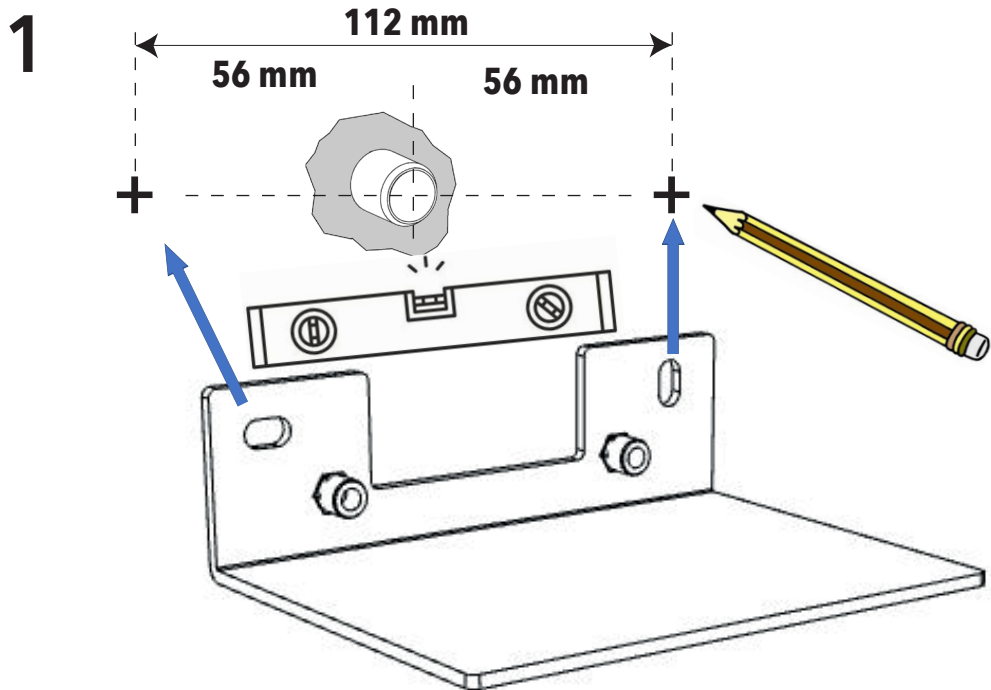

# SAFETY VALVE



1

La SAFETY VALVE (fig.1) viene applicata al soffione per garantire integrità meccanica evitando deformazioni e rotture, aumentando la durata nel tempo del prodotto.

La SAFETY VALVE entra in funzione quando si ha un improvviso aumento della pressione interna dovuta ad otturazione degli ugelli, sbalzo improvviso della pressione in entrata, o manomissione del prodotto come la rimozione del limitatore di portata preinstallato. In tutti questi casi la SAFETY VALVE si apre (fig.2) facendo uscire l'acqua e abbassando la pressione interna evitando il danneggiamento del soffione.

Effettuando la pulizia del soffione (fig.3) e reinserendo la SAFETY VALVE lo si riporta nelle condizioni iniziali di utilizzo.

Das SAFETY VALVE (Abb.1) wird am Duschkopf angebracht, um die mechanische Integrität zu gewährleisten, Verformungen und Brüche zu vermeiden und die Lebensdauer des Produkts im Laufe der Zeit zu erhöhen.

Das SAFETY VALVE schaltet sich ein, wenn der Innendruck plötzlich ansteigt, weil die Düsen verstopft sind, sich der Einlassdruck plötzlich verändert hat oder das Produkt manipuliert wurde, beispielsweise der vorinstallierte Durchflussbegrenzer entfernt wurde. In all diesen Fällen öffnet sich das SAFETY VALVE (Abb.2), lässt das Wasser austreten und senkt den Innendruck, um Schäden am Duschkopf zu vermeiden.

Durch Reinigen des Duschkopfes (Abb.3) und Wiedereinsetzen des SAFETY VALVE stellen Sie den ursprünglichen Betriebszustand wieder her.

The SAFETY VALVE (fig.1) is applied to the shower head to guarantee mechanical integrity, avoiding deformations and breakages, increasing the life of the product over time.

The SAFETY VALVE comes into operation when a sudden increase in internal pressure due to clogging of the nozzles occurs, a sudden change in inlet pressure, or tampering with the product such as the pre-installed flow limiter removal. In all these cases the SAFETY VALVE opens (fig.2), letting the water out and lowering the internal pressure, avoiding damage to the shower head.

By cleaning the shower head (fig.3) and reinserting the SAFETY VALVE you return it to its initial conditions of use.

By cleaning the shower head (fig.3) and reinserting the SAFETY VALVE you return it to its initial conditions of use.

La SAFETY VALVE (fig.1) É est appliquée sur la pomme de douche pour garantir l'intégrité mécanique, en évitant les déformations et les ruptures, augmentant ainsi la durée de vie du produit dans le temps.

La SAFETY VALVE entre en fonctionnement en cas d'augmentation soudaine de la pression interne due au colmatage des buses, à un changement soudain de la pression d'entrée ou à une altération du produit telle que le retrait du limiteur de débit préinstallé. Dans tous ces cas, la SAFETY VALVE s'ouvre (fig.2), laissant sortir l'eau et réduisant la pression interne, évitant ainsi d'endommager la pomme de douche.

En nettoyant la pomme de douche (fig.3) et en réinsérant la SAFETY VALVE vous la remettez dans ses conditions initiales d'utilisation.



2

**3**

**PULIZIA DEI SOFFIONI DOCCIA | REINIGUNG VON DUSCHKÖPFEN  
CLEANING OF SHOWERHEADS | NETTOYAGE DES POMME DE DOUCHE**



Al fine di prevenire possibili rotture del soffione si raccomanda di effettuare la pulizia periodica degli ugelli come raffigurato.

Um einen möglichen Bruch der Kopfbrause zu vermeiden, wird empfohlen, die Düsen regelmäßig wie abgebildet zu reinigen.

In order to prevent possible break-down of the shower head, is recommended a regular cleaning of the nozzles, as depicted.

Pour éviter une éventuelle rupture de la pomme de douche, il est recommandé de nettoyer régulièrement les buses comme indiqué.

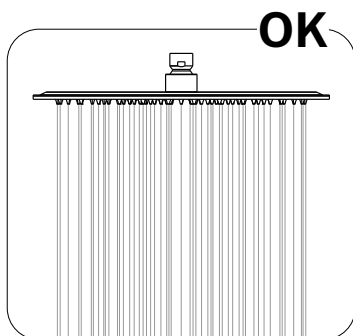

**Getto corretto - Richtiger Strahl  
Correct Jet - Jet Correct**

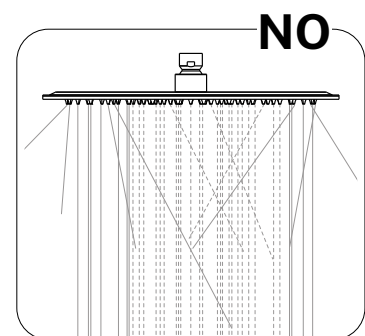

**Ugelli otturati - Düsen verstopft  
Nozzles clogged- Buses bouchées**

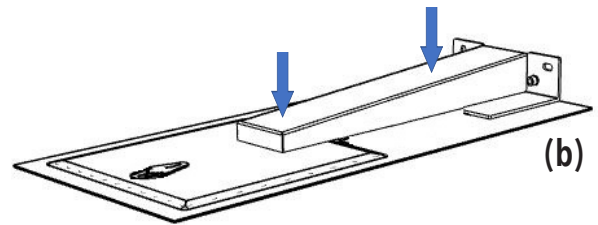
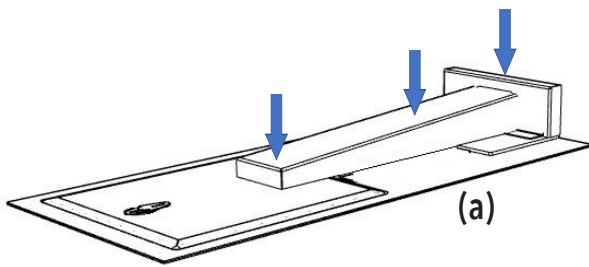

IT - Accessori non forniti  
 EN - Accessory not provided  
 DE - Zubehör nicht mitgeliefert  
 FR - Accessoire non fourni



**✗ IT - LA GARANZIA DEL PRODOTTO NON COPRE**  
 L'utilizzo improprio.  
 L'errata predisposizione dell'impianto idraulico.  
 Danni causati da depositi di calcare o altre impurità.  
 Detergenti non adatti.

**EN - NOT COVERED BY PRODUCT CARE**  
 Not correct use.  
 Incorrect setup of the hydraulic system.  
 Water impurities or limeston.  
 Not suitable detergents.

**DE - DIE PRODUKTGARANTIE DECKT NICHT AB**  
 Fehlerhafte Verwendung.  
 Die falsche Anordnung des Hydrauliksystems.  
 Schäden durch Kalkablagerungen oder andere Verunreinigungen.  
 Ungeeignete Reiniger.

**FR - LA GARANTIE DU PRODUIT NE COUVRE PAS**  
 Utilisation incorrecte.  
 La mauvaise disposition du système hydraulique.  
 Dommages causés par des dépôts de calcaire ou d'autres impuretés.  
 Nettoyants inappropriés.

**✓ IT - DUE ANNI DI GARANZIA DEL PRODOTTO**  
 Contro i difetti o vizi di fabbricazione.

**EN - TWO-YEAR PRODUCT CARE**  
 Against defects or defects of fabrication.

**DE - ZWEI JAHRE PRODUKTGARANTIE**  
 Gegen Mängel oder Herstellungsfehler

**FR - GARANTIE DE PRODUITS DE DEUX ANS**  
 Contre les défauts de fabrication ou les défauts.

**IT - ATTENZIONE:** Si declina ogni responsabilità relativa ad eventuali inesattezze contenute in queste istruzioni dovute ad errori di trascrizione.

**EN - WARNING:** We decline all responsibility and eventual inaccuracy contained in the instructions due to transcript errors.

**DE - ACHTUNG:** Wir lehnen jede Verantwortung für Ungenauigkeiten in diesen Anweisungen aufgrund von Transkriptionsfehlern ab.

**FR - ATTENTION:** Nous déclinons toute responsabilité pour toute inexactitude contenue dans ces instructions en raison d'erreurs de transcription.