

**IT - ISTRUZIONI DI MONTAGGIO**  
**EN - ASSEMBLY INSTRUCTIONS**  
**DE - MONTAGEANLEITUNG**  
**FR - INSTRUCTIONS DE MONTAGE**

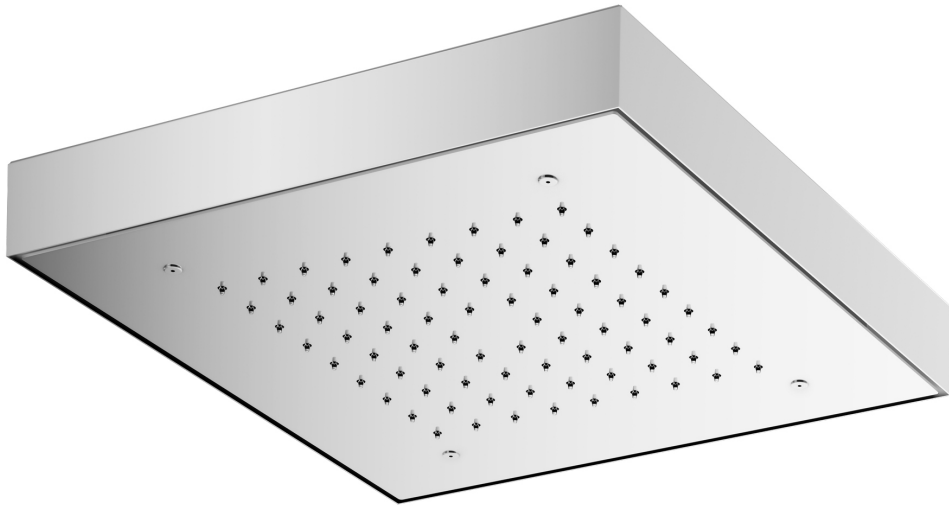

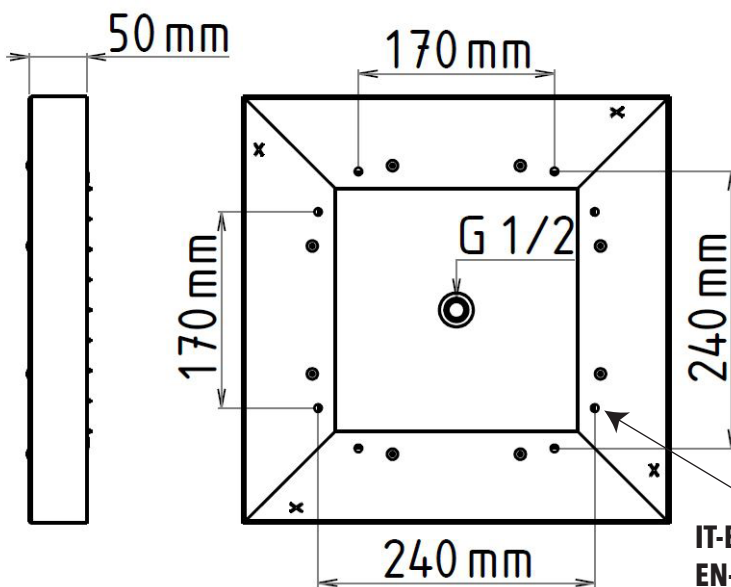

IT-Barra filettata  
EN-Threaded rod  
DE-Gewindestange  
FR-Tige filetée

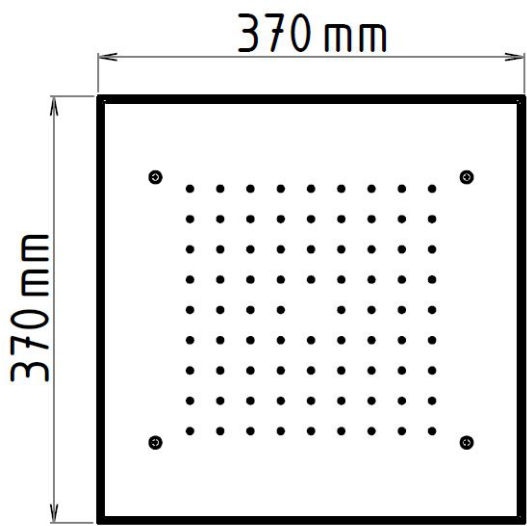
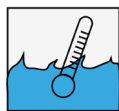

MAX 70°C  
BEST 38/40°C



MIN 1 Bar  
MAX 5 Bar  
BEST 3 Bar

IT-Dimensioni foro  
EN-Hole size  
DE-Lochgröße  
FR-Taille du trou

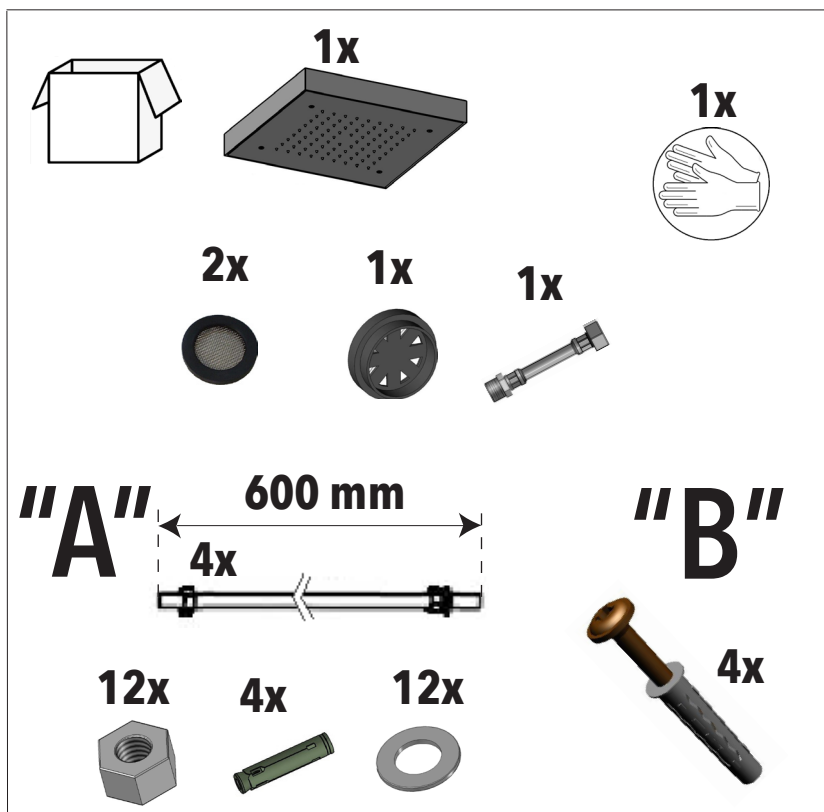
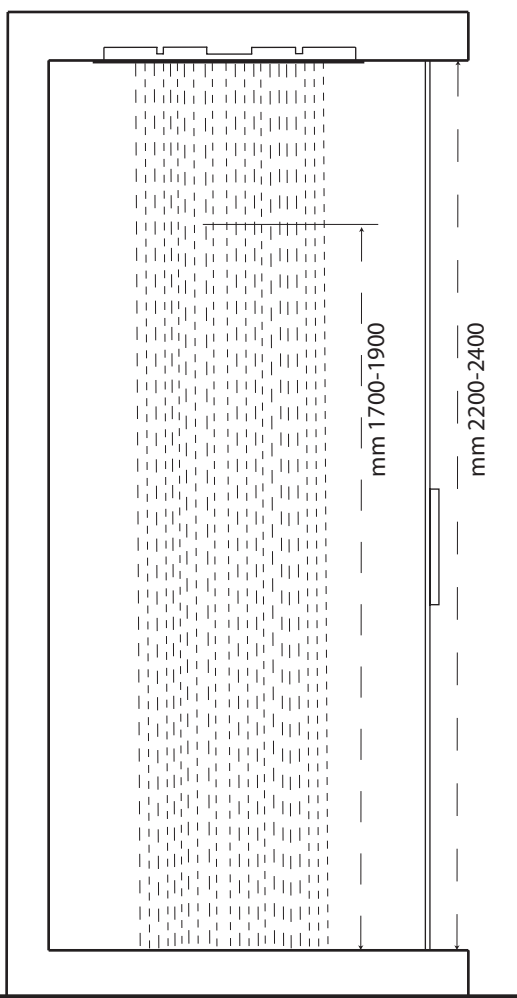
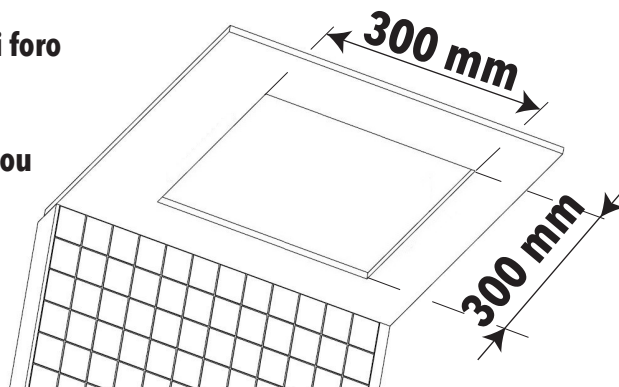

IT - L'apparechio deve essere installato da personale abilitato ai sensi e per l'effetto delle leggi in vigore.  
EN - According to the law, all installation and maintenance operations require a qualified person.  
DE - Das Gerät muss von qualifiziertem Personal gemäß den geltenden Gesetzen installiert werden.  
FR - L'appareil doit être installé par du personnel qualifié conformément et pour l'effet des lois en vigueur.

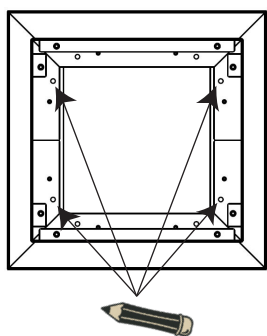
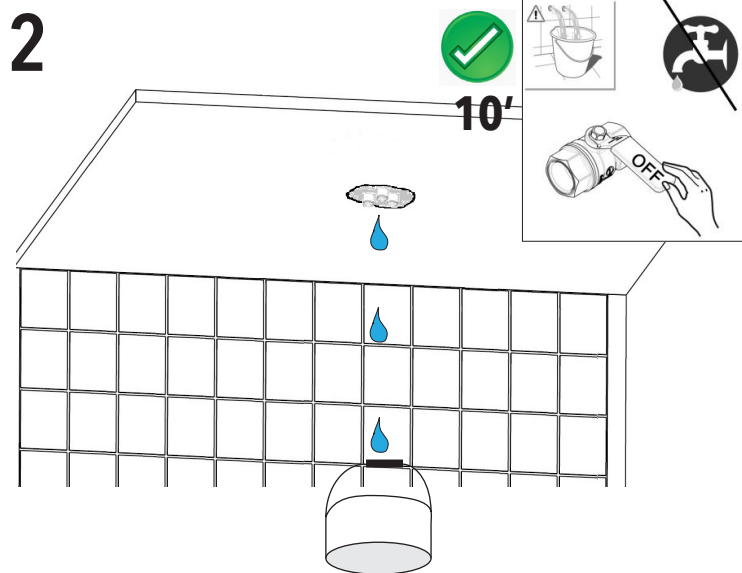
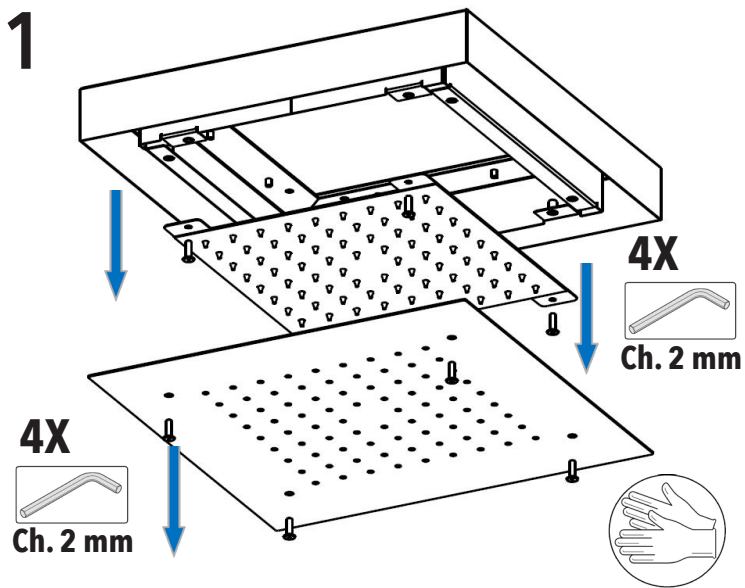

**"3A"**

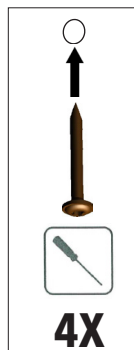
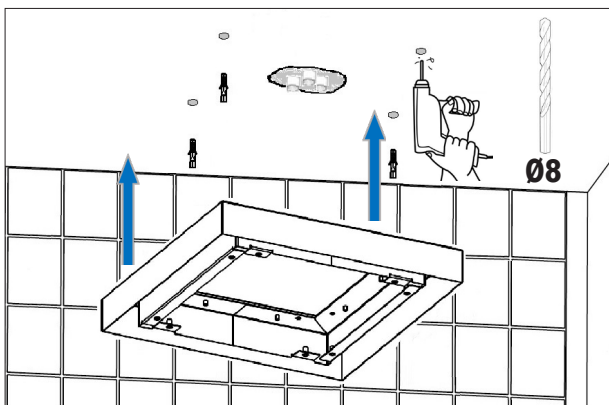
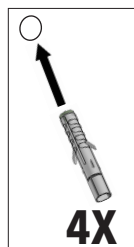

**"3B"**

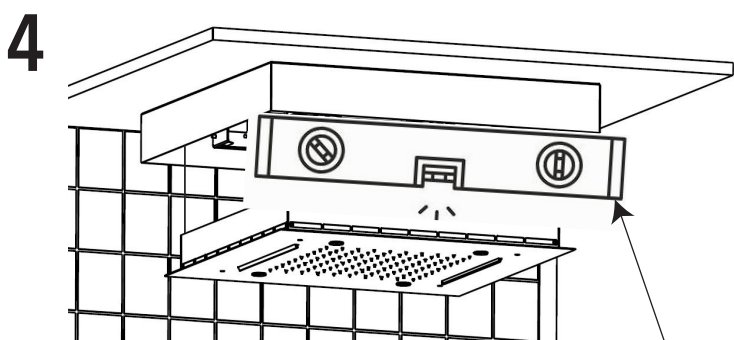
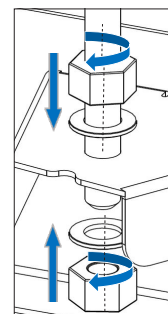
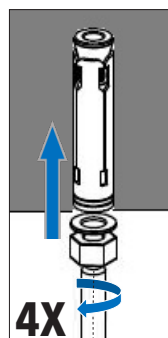
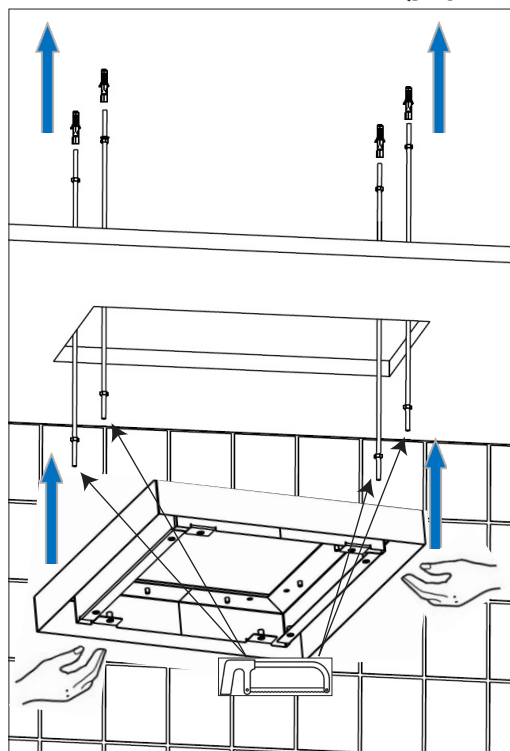
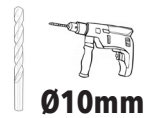

**IT-Telaio allineato al soffitto**  
**EN-Align frame to ceiling**  
**DE-Rahmen aus der Decke ausgerichtet**  
**FR-Instalaz le cadre bien aligné au plafond**

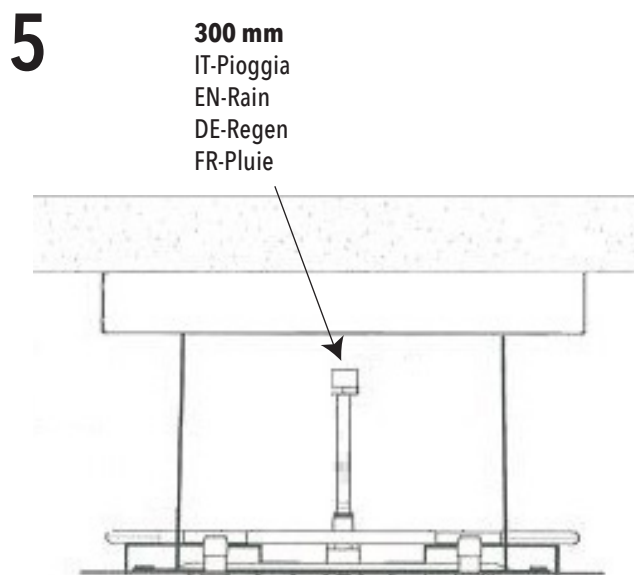

6

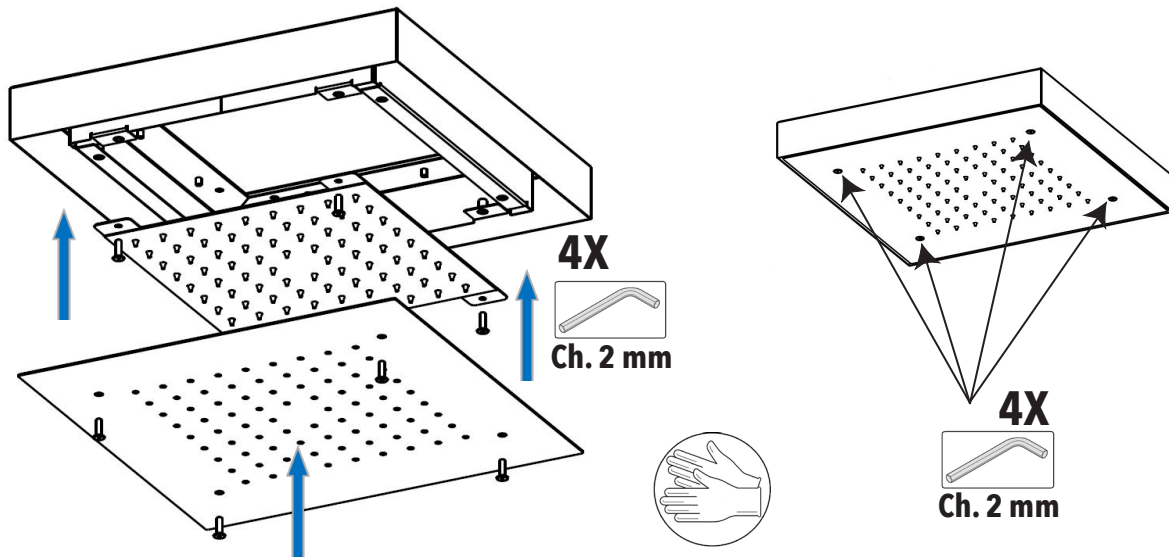

**IT - LA GARANZIA DEL PRODOTTO NON COPRE**

L'utilizzo improprio.  
L'errata predisposizione dell'impianto idraulico.  
Danni causati da depositi di calcare o altre impurità.  
Detergenti non adatti.

**EN - NOT COVERED BY PRODUCT CARE**

Not correct use.  
Incorrect setup of the hydraulic system.  
Water impurities or limestone deposits.  
Improper detergents.

**DE - DIE PRODUKTGARANTIE GILT NICHT**

Die falsche Verwendung  
Die falsche Anordnung des Hydrauliksystems.  
Schäden durch Kalkablagerungen oder andere Verunreinigungen.  
Ungeeignete Reiniger.

**FR - LA GARANTIE DU PRODUIT NE COUVRE PAS**

Utilisation incorrecte.  
La mauvaise disposition du système hydraulique.  
Dommages causés par des dépôts de calcaire ou d'autres impuretés.  
Nettoyants inappropriés.

**IT - ATTENZIONE:** Si declina ogni responsabilità relativa ad eventuali inesattezze contenute in queste istruzioni dovute ad errori di trascrizione.

**EN - WARNING:** We decline all responsibility for eventual inaccuracy contained in the instructions due to transcript errors.

**DE - ACHTUNG:** Wir lehnen jede Verantwortung für Ungenauigkeiten in diesen Anleitung aufgrund von Transkriptionsfehlern ab.

**FR - ATTENTION:** Nous déclinons toute responsabilité pour toute inexactitude contenue dans ces instructions en raison d'erreurs de transcription.



**IT - DUE ANNI DI GARANZIA DEL PRODOTTO**

Contro i difetti o vizi di fabbricazione.

**EN - TWO-YEAR PRODUCT CARE**

Against defects of fabrication.

**DE - ZWEI JAHRE LANG PRODUKTGARANTIE**

Gegen Mängel oder Herstellungsfehler

**FR - GARANTIE DE PRODUITS DE DEUX ANSO**

Contre les défauts de fabrication.