

IT - ISTRUZIONI DI MONTAGGIO
EN - ASSEMBLY INSTRUCTIONS
DE - INSTALLATIONSANLEITUNG
FR - INSTRUCTIONS DE MONTAGE

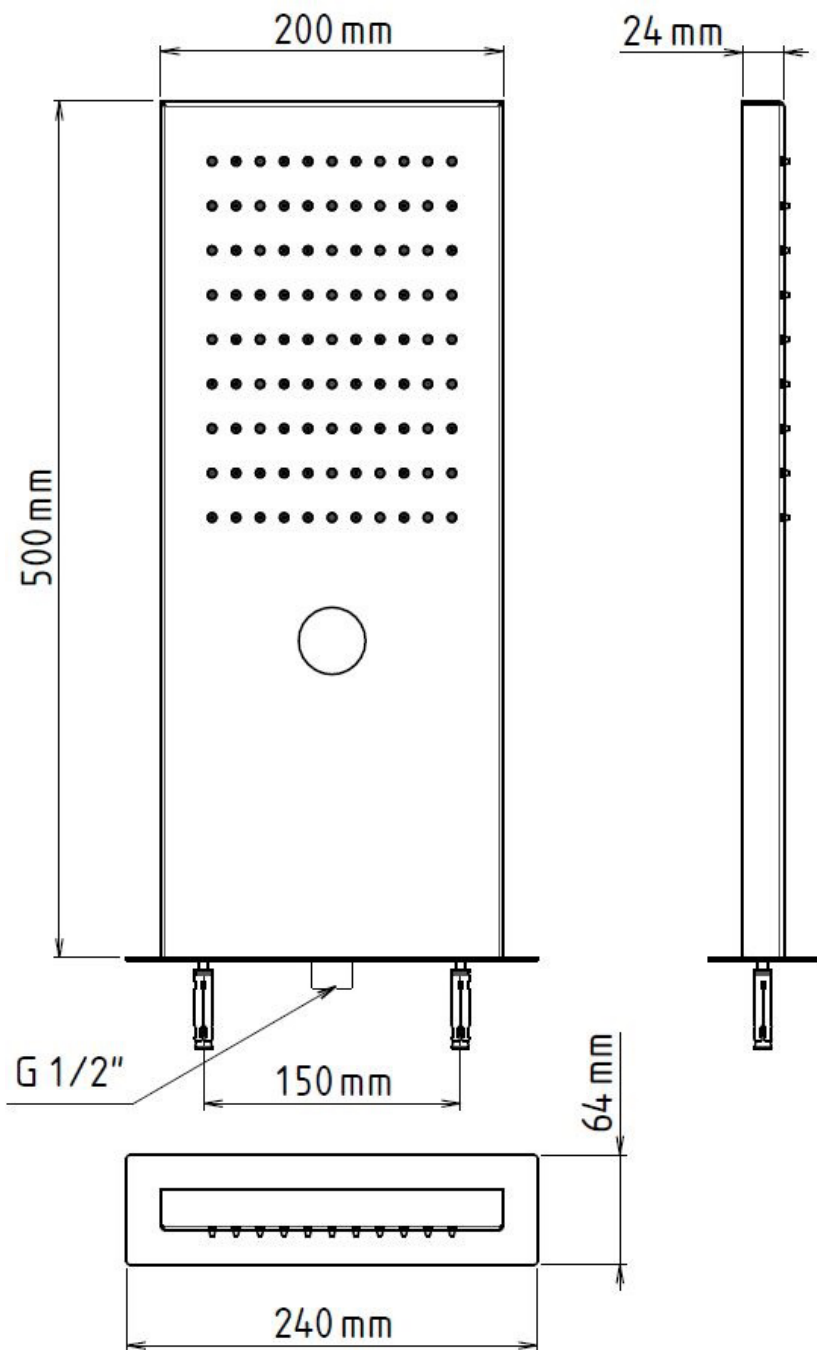

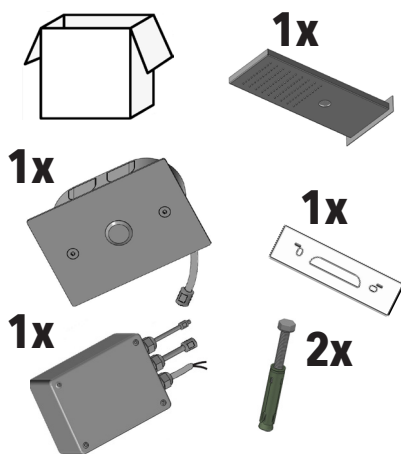

IT - Prima dell'installazione.
EN - Before installation.
DE - Vor der Installation.
FR - Avant l'installation

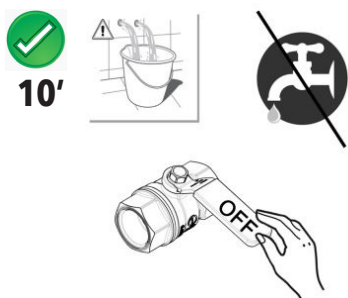

IT - Già montati sul soffione.
EN - Already mounted on the shower head.
DE - Bereits am Duschkopf montiert.
FR - Déjà monté sur la pomme de douche.



IT - L'apparecchio deve essere installato da personale abilitato ai sensi e per l'effetto delle leggi in vigore.
EN - According to the law, all installation and maintenance operations require a qualified person.
DE - Das Gerät muss von qualifiziertem Personal gemäß den geltenden Gesetzen installiert werden.
FR - L'appareil doit être installé par du personnel qualifié conformément et pour l'effet des lois en vigueur.

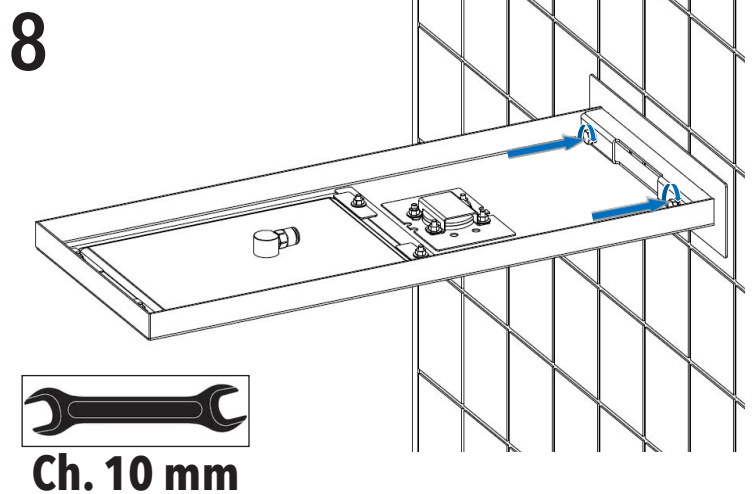
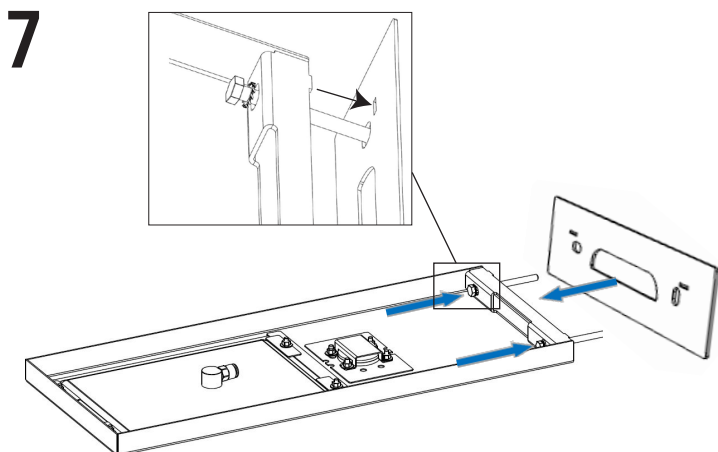
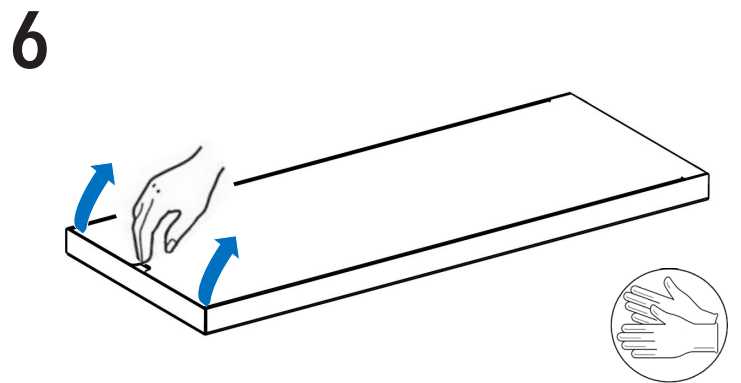
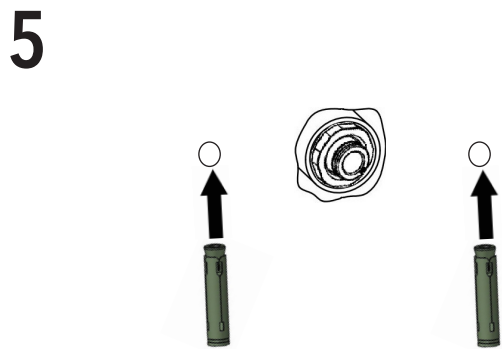
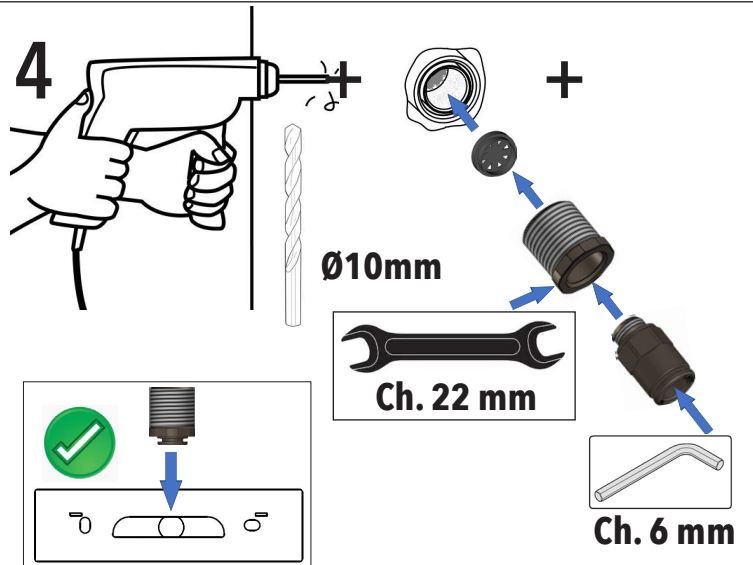
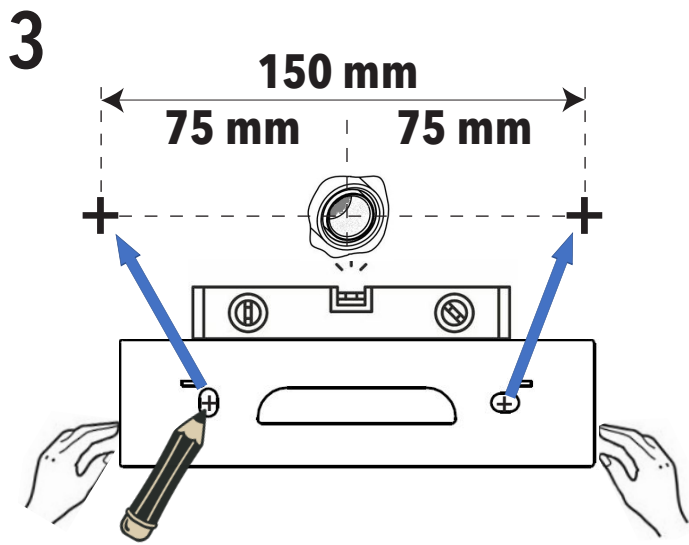
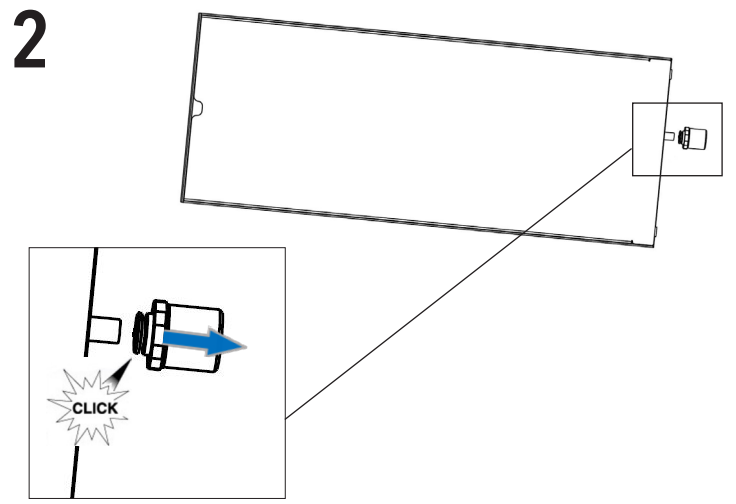
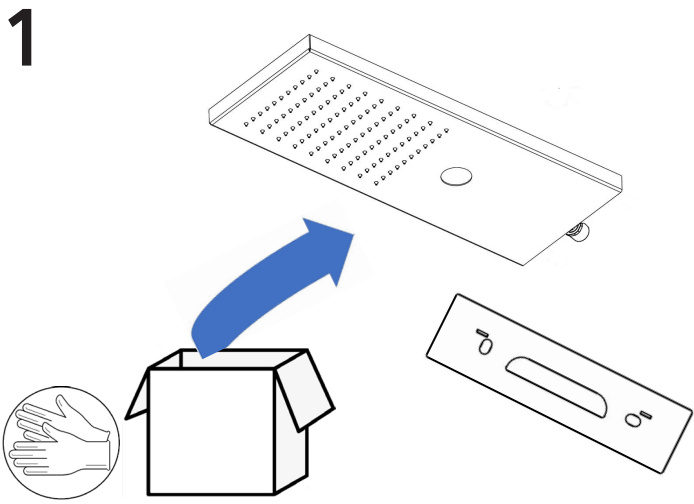

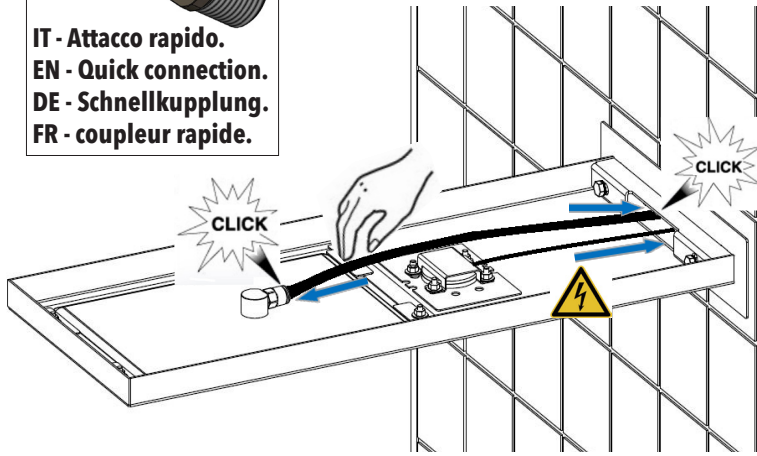
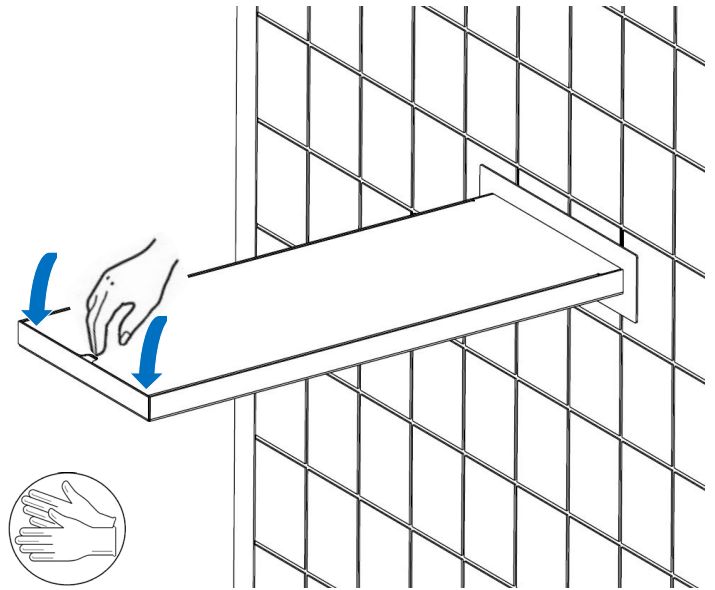
9**10**

CROMOTERAPIA - CHROMOTHERAPY - FARB THERAPIE - CHROMOTHÉRAPIE

IT - Comando incasso a muro
EN - In-wall control
DE - Wandeinbau
FR - Commande encastrée au mur



IT - Prima di qualsiasi operazione togliere sempre la tensione all'impianto.
EN - Always turn voltage off before performing any operation on the electric system.
DE - Vor jedem Vorgang immer die Spannung der elektrischen Anlage entfernen.
FR - Coupez toujours la tension avant d'effectuer toute opération.

IT - Installare l'alimentatore Class 2 - 12 Vac +/- 3% - Min. 35 VA nella zona 3 conforme alle distanze di sicurezza previste dalle normative CEI.

EN - Install the Class 2 - 12 Vac +/- 3% - Min. 35 VA device in zone 3, as per the IEC regulations about safety distance.

DE - Installieren Sie das Netzteil der Klasse 2 - 12 V DC +/- 3% - Min. 35 VA in Zone 3 gemäß den Sicherheitsabständen, die in den CEI-Vorschriften vorgeschrieben sind.

FR - Installez l'appareil Classe 2 - 12 Vca +/- 3% - Min. 35 VA dans la zone 3 en respectant les réglementations CEI sur la distance de sécurité.

IT - Collegamento elettrico
EN - Electrical connection setup
DE - Aufbau der elektrischen Verbindung
FR - Configuration de la connexion électrique

IT-Tensione EN-Voltage DE-Stromspannung FR-Tension	Frequenza Frequency Frequenz La fréquence	Potenza nominale Max. Max. rated power input Max. spezifizierte Leistung Max. puissance d'entrée nominale	Grado di protezione parti elettriche Protection level of electrical parts Schutzgrad für elektrische Teile Niveau de protection des pièces électriques	Grado di protezione pulsante Button protection level Schutzgradknopf Niveau de protection des boutons
100-240 VAC	50-60 Hz	30 W	IP55	IP64

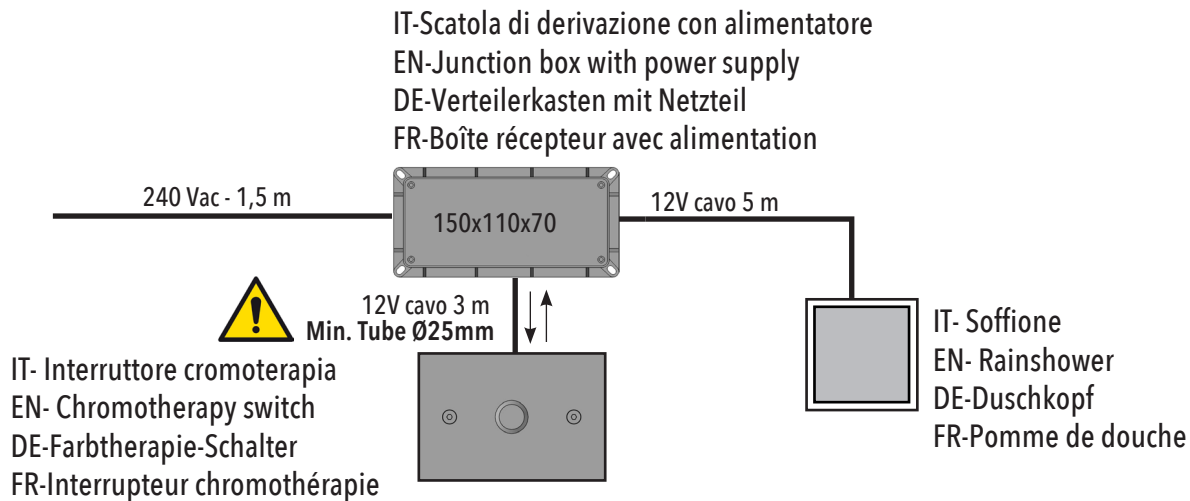

IT-Modalità di funzionamento LED RGB

EN-Mode of operation of the RGB LED

DE-Funktionsweise der RGB-LED

FR-Mode de fonctionnement de la LED RVB

IT- Sequenza colori: Bianco - Rosso - Verde - Blu - Giallo - Fucsia - Azzurro.

EN- Color sequence: White - Red - Green - Blue - Yellow - Fuchsia - Bright Blue.

DE-Farbfolge: Weiß - Rot - Grün - Blau - Gelb - Fuchsia - Hellblau.

FR-Séquence de couleurs: blanc - rouge - vert - bleu - jaune - fuchsia - bleu vif.

IT- Premere una volta il tasto: ACCESO.

EN- Press the key once: POWER ON.

DE- EDrücken Sie die Taste einmal: EINGESCHALTET.

FR- Appuyez une fois sur la touche : ALLUMÉ.

IT- Ripremere il tasto: Scelta manuale del colore.

EN- Press the button again: Manual color selection.

DE- Drücken Sie die Taste erneut: Manuelle Auswahl der Farbe.

FR- Appuyez à nouveau sur le bouton: Choix de couleur.

IT- Premi per 2 secondi il tasto: Cromoterapia modalità automatica, rotazione colori come sequenza ogni minuto.

EN- Press the button for 2 seconds: Automatic chromotherapy, color rotation every minute following the sequence above.

DE- Drücken Sie die Taste für 2 Sekunden: Automatische Farbtherapie, Farbrotaion als Sequenz jede Minute.

FR- Appuyez sur le bouton pendant 2 secondes : Chromothérapie mode automatique, rotation des couleurs en séquence toutes les minutes.

IT- Premere 2 volte consecutivamente il tasto: SPENTO.

EN- Press the button twice consecutively: TURNED OFF.

DE- Drücken Sie die Taste zweimal hintereinander: AUSGESCHALTET.

FR- Appuyez sur le bouton deux fois de suite: ÉTEINDRE.

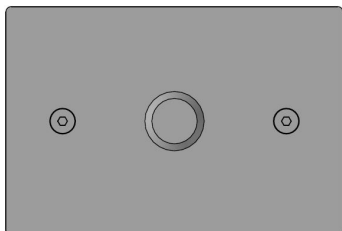

IT- Predisposizione elettrica
EN- Electrical setup
DE- Elektrische Veranlagung
FR- Installation électrique

IT- Soffione
 EN- Rainshower
 DE-Duschkopf
 FR-Pomme de douche

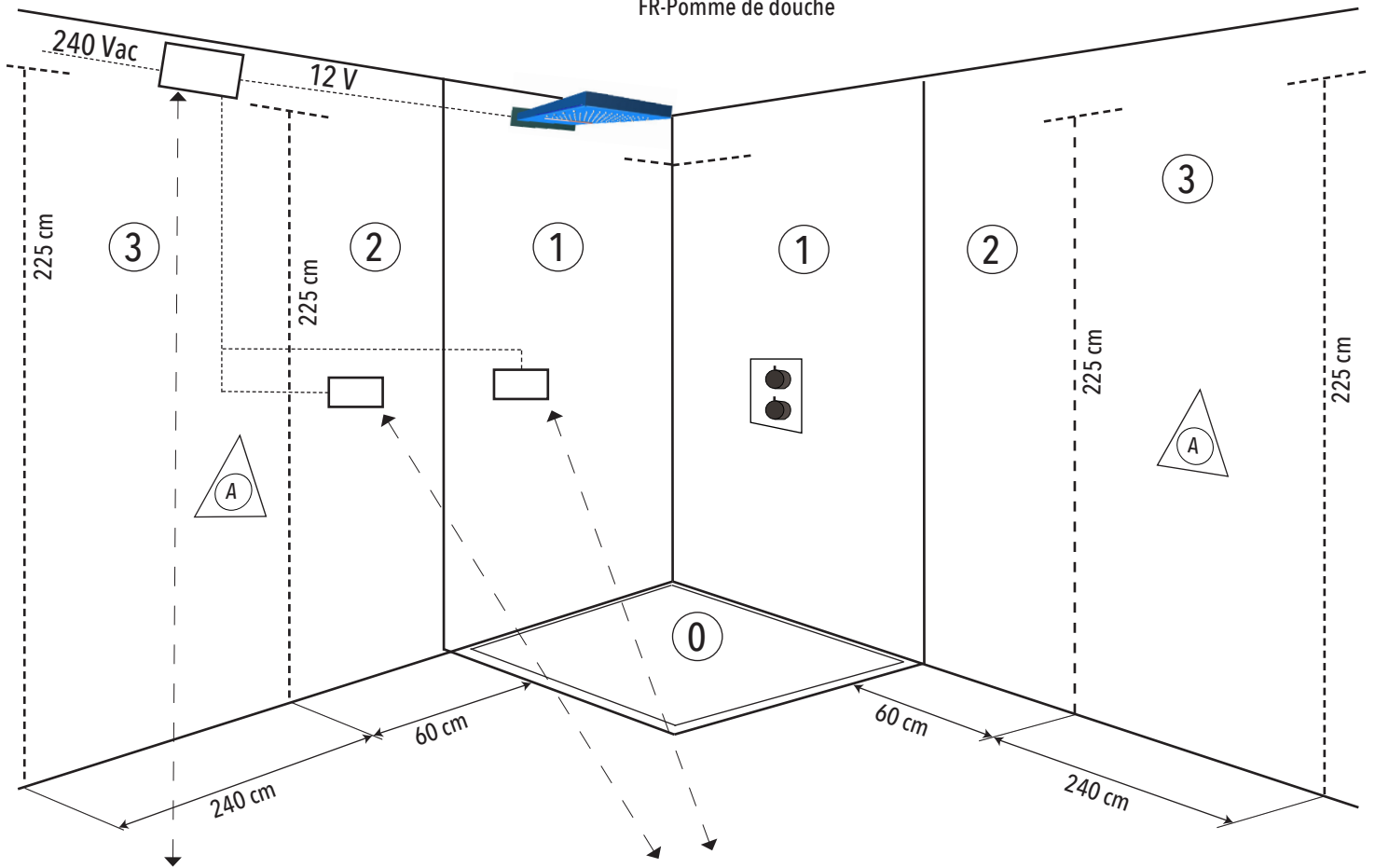

IT- SCATOLA DI DERIVAZIONE

Ipotetica posizione per scatola di derivazione
 (cavo di 1,5 m 240Vac, esterna a cabina doccia).

EN- JUNCTION BOX

Ideal position of the in-wall junction box
 (cable: 1.5 m, 240Vac. outside the shower box).

DE- VERTEILERKASTEN

Bestmögliche Position für Verteilerkasten (1,5 m
 240 VAC Kabel, außerhalb der Duschkabine).

FR- BOÎTE RÉCEPTEUR

Position hypothétique de la boîte de jonction dans
 le mur (câbles de 1,5 m, 240 Vac. l'extérieur de la
 cabine de douche).

IT- Ipotetica posizione per pulsantiera cromoterapia (cavo di 3m 12V).

EN- Hypothetical position for chromotherapy button panel (3m 12V cable).

DE- Hypothetische Position für das Chromotherapie-Tastenfeld
 (3 m 12 V-Kabel).

FR- Position hypothétique du panneau de boutons de chromothérapie
 (câble 12V 3m)



Norme CEI

IEC regulations

IEC-Normen

IT- Zona (3) d'installazione della scatola di derivazione.

EN- Installation area (3) for the junction box.

DE- Gebiet (3) der Installation des Verteilerkasten

FR- Zone d'installation (3) de la boîte de jonction.

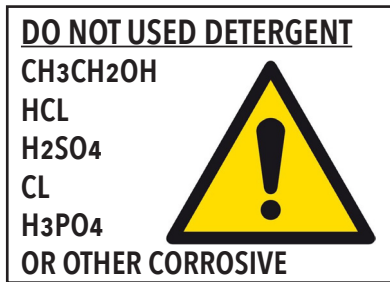

IT - LA GARANZIA DEL PRODOTTO NON COPRE

L'utilizzo improprio.
L'errata predisposizione dell'impianto idraulico.
Danni causati da depositi di calcare o altre impurità.
Detergenti non adatti.

EN - NOT COVERED BY PRODUCT CARE

Not correct use.
Incorrect setup of the hydraulic system.
Water impurities or limeston.
Not suitable detergents.

DE - DIE PRODUKTGARANTIE DECKT NICHT AB

Fehlerhafte Verwendung.
Die falsche Anordnung des Hydrauliksystems.
Schäden durch Kalkablagerungen oder andere
Verunreinigungen.
Ungeeignete Reiniger.

FR - LA GARANTIE DU PRODUIT NE COUVRE PAS

Utilisation incorrecte.
La mauvaise disposition du système hydraulique.
Dommages causés par des dépôts de calcaire ou
d'autres impuretés.
Nettoyants inappropriés.



IT - DUE ANNI DI GARANZIA DEL PRODOTTO

Contro i difetti o vizi di fabbricazione.

EN - TWO-YEAR PRODUCT CARE

Against defects or defects of fabrication.

DE - ZWEI JAHRE PRODUKTGARANTIE

Gegen Mängel oder Herstellungsfehler

FR - GARANTIE DE PRODUITS DE DEUX ANS

Contre les défauts de fabrication ou les défauts.

IT - ATTENZIONE: Si declina ogni responsabilità relativa ad eventuali inesattezze contenute in queste istruzioni dovute ad errori di trascrizione.

EN - WARNING: We decline all responsibility and eventual inaccuracy contained in the instructions due to transcript errors.

DE - ACHTUNG: Wir lehnen jede Verantwortung für Ungenauigkeiten in diesen Anweisungen aufgrund von Transkriptionsfehlern ab.

FR - ATTENTION: Nous déclinons toute responsabilité pour toute inexactitude contenue dans ces instructions en raison d'erreurs de transcription.

